

# REVOLUTION® SP

## HIGH-VOLUME/LOW-SPEED FANS

### Greater energy efficiency and cost savings

- ▶ Costs pennies an hour to operate
- ▶ Reduce energy consumption by 20-30%

### Increased comfort and productivity

- ▶ Cooler in summer
- ▶ Warmer in winter

### Optimized airflow

- ▶ Uniform air velocity
- ▶ No dead air "holes" under center of fan

### Delivered with confidence

- ▶ 1-year Customer Satisfaction Money-Back Guarantee
- ▶ 10-year structural integrity warranty
- ▶ Lifetime warranty on workmanship of blades and hub
- ▶ 3-year parts and 1-year labor warranty



## STYLE WITH PERFORMANCE

Take comfort to new highs and costs to new lows with a look that is nothing short of Revolutionary. Revolution® SP Fans, form and function in perfect balance.

**RITE·HITE®**



### Unique blade design

- ▶ Polished aluminum blade with Vortex tips combine style with performance
- ▶ Ideal contour and twist for maximum air movement

### Upward blade tilt

- ▶ Increases airflow and reach
- ▶ Extends reach of air movement up to 50' from the fan's center in all directions
- ▶ Directs air outward from fan's center in a conical shape

### Resilient blade/hub connection

- ▶ Vibration-absorbing material reduces stress to the hub by 50 to 75%
- ▶ Rotationally balanced blade/hub
- ▶ Used for over 40 years in the most demanding applications worldwide
- ▶ Designed for over 10 times the force and stress generated by the Revolution SP Fan

### Robust mounting system

- ▶ Extruded, precision-milled aluminum hub
- ▶ Three-way motor-to-hub safety connection

### Easy-to-use controls

- ▶ Simple on/off button
- ▶ Adjustable speed control
- ▶ Operates in forward or reverse
- ▶ Fits into standard electrical housing

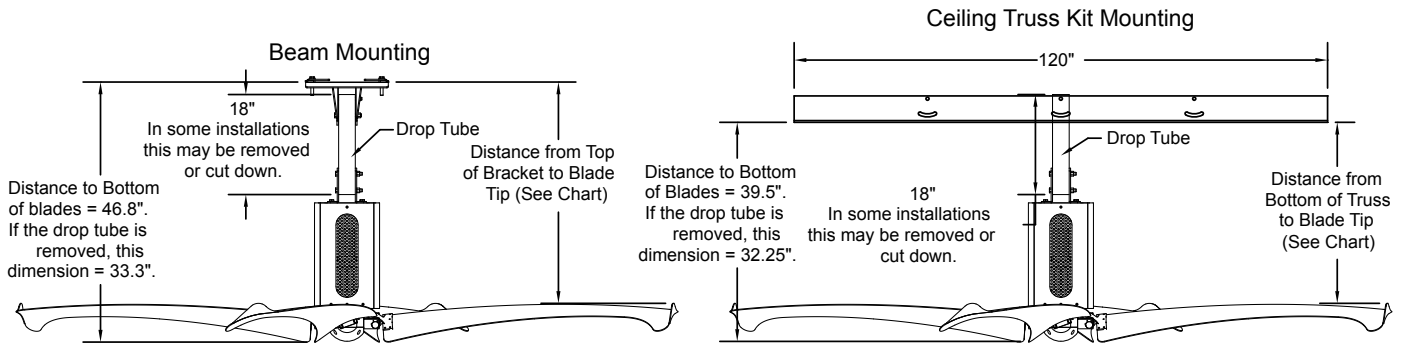
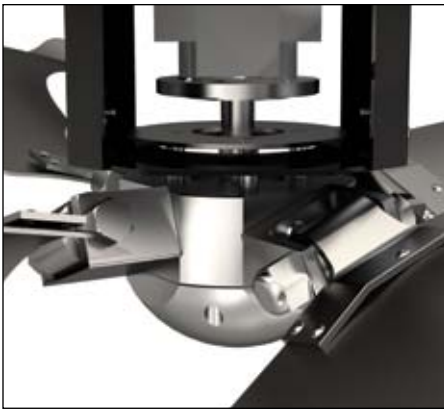

Beam Mounting

Ceiling Truss Kit Mounting

| Diameter | Airflow 4 Blade | Speed  | Weight | Distance From Top of Bracket to Blade Tip* |          |
|----------|-----------------|--------|--------|--|----------|
|          |                 |        |        | At Rest                                    | Full RPM |
| ft       | cfm             | rpm    | lb     | in   | in       |
| 8'       | 50,000          | 20-120 | 140    | 40.0                                       | 40.0     |
| 10'      | 75,000          | 17-100 | 145    | 40.0                                       | 39.25    |
| 12'      | 100,000         | 13-80  | 150    | 40.0                                       | 38.5     |

| Distance From Top of Bracket to Blade Tip* | Distance From Top of Bracket to Blade Tip* |          |
|--|--|----------|
|  | At Rest                                    | Full RPM |
| in   | in   | in       |
| 32.75                                      | 32.75                                      | 32.75    |
| 32.75                                      | 32.0                                       | 32.0     |
| 32.75                                      | 31.25                                      | 31.25    |

\* Optional extension kit available to increase dimension if necessary .



8900 North Arbon Drive Milwaukee, WI 53223 USA (414) 362-6377 (888) 423-0789 FAX: (414) 355-9248

Mailing Address: Rite-Hite P.O. Box 245020 Milwaukee, WI 53224 USA

[www.ritehite.com](http://www.ritehite.com) [www.ritehitefans.com](http://www.ritehitefans.com)

RITE-HITE® and Revolution® are trademarks of the RITE-HITE Holding Corporation.

RITE-HITE products may be covered by one or more U.S. Patents with other U.S. and foreign patents pending. RITE-HITE reserves the right to make product improvements without prior notice.